

Triangle Chapter News



October 2017

October News Summary

(Story summaries here. See the stories in the matching sections below.)

1. **Upcoming Triangle Events/Calendar** – Remember to attend the NC Region Meet in Spencer, October 14, 2017. Also mark down the Triangle Chapter Chick-Fil-A display November 11, 2017.
2. **Next Triangle Chapter meeting.** Our next meeting will be 6 pm, October 19, 2017 at Golden Corral. Program to be announced.
3. **President's Corner.** See Jim's article about his Hershey experience.
4. **Editors' Notes.** As announced Denny will be giving up the editor's position at the end of 2017. Three more issues. If you would like to step up please contact Jim Gill or contact Denny for further information about how you can help.
5. **Treasurer's Updates.** Marv Gage has received new Chapter Shirts and will have them at the next meeting. Contact Marv if you have a request. 2018 Dues can be submitted, See the dues form at the end of this newsletter.
6. **Notes from our September meeting** by Dean Tryon.
7. **Car Shows, Events, and Cruise-Ins;** See Annie's List of car shows and cruise-ins
8. **American Legion Car Show.** Story and pictures by Annie Goldman.
9. **Triangle Chapter Picnic** Report and pictures by Andrea Irby
10. **Yates Mill Historic Park Display Report.** Story and Pictures by Annie Goldman
11. **Oak View Historic Park Display Report.** Story and Pictures by Denny Oestreich
12. **Hershey Pictures.** Pictures by Les and Dean Tryon and Joe Parsons..
13. **Tool Wizard challenge.** There was no September Wizard. Can you identify the October mystery tool?
14. **AACA Judging of Headlights.** A technical article by Mike Peterson.
15. **For Sale.** 1957 Chevy 2 Door Sedan with Fuel Injection for sale.
16. **Triangle Chapter Contacts.** Whom to contact if you have club ideas or questions.

1. Triangle 2017 Upcoming Events Calendar

October 19 - Triangle Chapter Regular Meeting at Golden Corral. 6 pm.

November 11 – Chick-Fil-A display.

November 16 - Triangle Chapter Regular Meeting at Golden Corral. 6 pm.

December 3 - Triangle Chapter Holiday Gathering at the Stag Club in North Raleigh.

January 19-20, 2018 – Plan to attend the NC Region Annual meeting in Burlington, NC. Details will be forthcoming.

2. Next Triangle Chapter Events

EVENT #1

What: Triangle Chapter monthly meeting.

When: Thursday evening, October 19, 2017.

Where: Golden Corral on Glenwood Avenue

Times: Dinner starts at 6 pm; Meeting will start at 7:00 pm: Program starts at 7:30

Program Topic: To be announced.

Event #2

What: Chick-Fil-A Display

When: Saturday November 11, 2017 9:30 am to 3 pm.

Where: Chick-Fil-A at 4621 Capital Boulevard, Raleigh, NC.

Details: This is a cruise-in display that the Triangle has been doing for many years. We invite other members of the community to drive in and join us. Often we get new members for the Triangle Chapter from this event. No judging, no pressure. Free lunch. They will have the parking areas designated. Rain date is November 18, 2017

3. President's Corner

By Jim Gill

Do you all recall the phrase "You never get to old to try something new"? I have heard from a number of club members who speak about the "Hershey Experience" and how it is something that I had to do. Well, this past weekend I did and enjoyed it immensely. The Hershey Experience is really an experience. Now, we all have been to numerous car shows in other states but this one was unique. It was well attended by Triangle members as I counted 22, three receiving awards at the closing banquet. My chauffeur, Annie, took me to the various swap meet areas, the cars and coffee event, the museum, the auction, and the library. In the library with AACA employee help we got to read an article from a newspaper printed June 22nd 1924 on the Model T snowmobile. Further digging we found some actual Model T brochures from the Arps Corporation of New Holstein, WI explaining the new tread design and "electric welded" skis for greater steering control. All along I thought I had a "Snow Flyer" snowmobile and reading during a slow time at the election I found out I actually do have the "Snow Bird" design as indicated in this brochure. Lastly, we attended the actual Hershey car show followed by the banquet. The array of vehicles on the field was mind boggling with heavy attendance around the 1930's classics. One "experience" that stood out in my mind was the car show entry; without a doubt, unique from all other car shows I have attended.

Yes, the "Hershey Experience" was indeed an experience and I encourage those that have not attended to place it on your bucket list. Looking forward to next year's event.

4. Editors' Notes

Editors: Denny Oestreich and Annie Goldman

Article Deadlines:

Now that everyone is home from summer vacations, family visits, general travelling, it's good to see more members at local events. Fall is a beautiful time to be out - the vehicles love the cooler weather like most of our members do!

The monthly newsletter is published a week before each meeting. Our meetings are on the 3rd Thursday each

month (We do not meet in July or August, but we still publish a newsletter). The deadline for submitting an article is the 2nd Thursday each month. We love to get your articles. Some ideas:

- Tell us how about the newest car you just got.
- Tell about car shows you attended.
- Tell us about car related things you saw or did on vacation.
- Tell us about the most fun you ever had in your car.
- Include links to your pictures. Even in PDF you can click on links to pictures in the newsletter
- We especially enjoy pictures of your car projects. Please send or give your pictures and articles to Denny (OestreichD@AOL.com) or Annie at: anniesss@gmail.com.

Printing help

If you have trouble printing our newsletter from Email, please contact Denny at: OestreichD@AOL.com. I can send you a Word document, imbed it in an Email or even send you a paper copy..

Web Site and Facebook

If you want to see ongoing updates to Triangle Activities try, looking at our Website or Facebook site. Both have many more pictures and updates of Triangle activities.

- Triangle Website: <http://www.ncregionaaca.com/triangle/>
- Triangle Facebook: <https://www.facebook.com/NCRegionAACA/>
- NC Region Website: <http://www.ncregionaaca.com/region/>

Newsletter Corrections:

We make corrections and additions to the online version of the newsletter. If you send corrections to Denny, I will make the changes and update the website copy which you can download and reprint. If you want to reprint the newsletter the latest PDF version is always on our web page at:

<http://www.ncregionaaca.com/triangle/>.

5. Treasurer's Updates

By Marv Gage

2018 Dues

AACA membership dues are due by December 31, 2017. If they are not paid by that date you will not be able to sign up for National Shows, Tours or Judging in 2018. I have attached a 2018 Membership Renewal Dues form to the newsletter for your convenience. You can pay National, Region and Chapter dues to the Club and we will send them to the proper organization for you. **Please note the National Dues have increased to \$40 for 2018.** If you have any questions, you can contact me at mkgage@aol.com or [919-846-4708](tel:919-846-4708).

Club Shirts

Marv Gage has a received a supply of polo shirts with Triangle Chapter logos. so if you want something special contact Marv.

- Men's gray shirts without pockets in a polyester material.
- These are good since they are cooler.
- Comes in medium, large, and X-large sizes. \$25.00.
- Men's traditional men's navy blue cotton and polyester blend with pockets.
- Sizes medium, large and X-large for \$20.
- Men's traditional navy blue shirts without pockets
- Sizes in large and X-large for \$20.
- Ladies navy blue.
- Sizes Medium and Large for \$20.

If you ordered a shirt or would like a shirt please contact Marv Gage at the next dinner meeting or he can be reached at either mkgage@aol.com or [919-846-4708](tel:919-846-4708).

6. Triangle Chapter Meeting Notes 9/21/2017

By Dean Tryon

Action Items and Upcoming Events: *(details are in the newsletters)*

1. Oct 7 – Heritage Days at Oak View Park. Marv requested 12 cars but many members will be at Hershey. The time is 9:30-3 with lunch provided. No judging, just a fun day. Call Marv Gage if you can attend (919-846-4708)
2. Oct 14 – Region Fall show at Spencer. Advanced registration required.
3. Dec 14 - NC President Bill Cox is encouraging all to participate in the Hillsborough Holiday Tour. They are looking for cars of specific years.

General discussion:

1. Jim Gill opened the meeting and introduced guests Kevin Scott (1920 T), Chip Weber, and John Gerken's son.
2. Marv Gage reported that membership is up to 98 families and the treasury is in good shape with \$7250. AACA National membership has gone up \$5 to \$40/year.
3. Sandra Reiner thanked all the members for their support during her recent surgery and her on-going recovery. She is planning on the annual trip to Hershey with a walker in hand.
4. Information on recent shows is documented in the last newsletter so will not be repeated here. The 9/17 picnic at Andrea and Cecil Bozarth's was well attended with over 50 people and plenty of food. Thanks to the Bozarth's for hosting this for the third time.
5. Newsletter Editor – this position is still open. We thank Denny for helping as long as he has. Call Denny Oestreich (pronounced "A-strike") if you need further info – 919-846-8163 (Additional info - The Chapter is paying the editor \$100/issue and all distribution is by e-mail.)
6. Several members mentioned the status of their restoration projects.
 - a. Chet Butcher has brought a 1.5 Ton Ford truck to NC
 - b. Jim Gill has completed painting his current project. He also is bringing to NC a 1926 snowmobile – you will have to ask him why!
 - c. Marilee is still cleaning out Glen's car stuff and has considerable literature.
7. The Chapter members donated many flood relief items and filled a Suburban.
8. The program was a presentation by Dean and Les Tryon on the Buick Heritage Alliance award in July during the Buick Club's annual meeting. More info is in the July newsletter. This topic continues the May meeting where members gave some info on their background and careers. You can also see the 20 min You Tube video at:

<https://www.youtube.com/watch?v=IGYtnJmVxWI&feature=youtu.be>

Or search on You Tube for "Dean Tryon Tribute 2017".

7. Car Shows, Events, and Cruise-ins

By Annie Goldman

See the NC Region Web site or your NC Region Newsletter for more details about AACA events:
<http://www.ncregionaaca.com/region>

If you know of another show not listed, please email me to add them to the calendar at AnniesSS@gmail.com.

Upcoming AACA Events: See all of the AACA National and Chapter Events and Tours here:
http://www.aaca.org/Calendar/aaca_calendar.html

October 14 - NC Region Fall Meet, NC Transportation Museum, Spencer

Other 2017 Chapter Events and Local Shows:

October 14 - 7th Annual Car Truck Bike Show, Holly Springs United Church, 3rd St, Holly Springs

October 28 - Percy Flowers car display & Take-A-part T

November 11 – Chick-Fil-A Car display.

Monthly Cruise-Ins - some will not run year round:

1st Saturday of the Month	Char-Grill Cruise-in, 4617 Atlantic Ave, Raleigh 4pm
1st Saturday of the Month	Siler City Cruise in, AutoZone/Sonic 1509 E 11th St, Siler City 5-8pm (Apr-Oct)
1st Saturday of the Month	MoJo's Grill, 2648 Timber Dr, Garner, 4-9pm (Apr-Oct)
2nd Saturday of the Month	Southland Car Club, Pizza Hut 725 N Brightleaf Blvd, Smithfield 3pm
2nd Saturday of the Month	Old Salem Chapter, Downtown Main St, Kernersville (4-7pm, June-October)
3rd Friday of the Month	Timeless Cruisers, 1318 Mebane Oaks Rd, Mebane
3rd Saturday of the Month	General Greene Chapter Cars n Coffee, UNCG Campus 550 Tate St, Greensboro NC (behind Weatherspoon Art Museum) (March-November)
3rd Sunday of the Month	Boston Market, 4558-A Capital Blvd, Raleigh (April-October)
4th Saturday of the Month	Cars n Coffee, 950 Gateway Commons, Wake Forest
4th Saturday of the Month	Mopar Motivators, 2108 S Main St, Wake Forest

Want to be included in the Evite sent out for various car shows, etc. and aren't getting it? Send Annie (AnnieSS@gmail.com) an email from the email address you want added with a short note and you'll start receiving the reminders each time they are sent.

8. American Legion Car Show Sept, 2017

By Annie Goldman

The American Legion in Fuquay Varina held a great show on Sunday September 24. While not a big show, the vehicles in attendance were great and included three Triangle Chapter members: Jim Gill, Carl Worstell and myself. The car show is held to raise funds for veterans and also have a 50/50 and some great raffle prizes. Burgers and hot dogs were available for purchase and they even had homemade sugar cookies.





9. Triangle Annual Picnic September 17, 2017

By Andrea Irby

The Party at the Pond House was amazing. We had close to 50 club members and their families attend our chapter's annual picnic. There was great food, camaraderie and of course, beautiful old cars to see. Some of the highlights include: Sandra Reiner making her return to car club activities. Everyone enjoyed catching up with her and seeing her in good health again. Kudos to Riley who drove his Model T all the way from Wake Forest. It is a long journey from the top of Wake County to the bottom and we appreciate him bringing his car as always.



The "Horsepower" Barn with Cecil's Lincolns



Dudley Morrison's Volvo with over 300,000 Miles



Fred and Sue Harley's Model- T



Ted Brooks '57 Chevy, Good Behavior Award



Riley and Sandra Reiner's Model-T



Steve Cooks 1941 Ford

Dudley Morrison brought his antique Volvo and a really great pie that disappeared quickly. Ted Brooks brought his 57 Chevy, but Denny left his at home after it had some hiccups starting out. Barb Van Dewoestine brought a great dessert that she made from her mother's recipe box. Chicken was also in high demand. Andrea's Greek grilled chicken and Pat Allen's fried chicken got gobbled up and we even had a bit of salmon from the smoker. The Goldmans brought enough baked Ziti to feed an army (they know how we eat)! There was also an amazing summer salad of spinach, summer berries and sweet pecans that was delicious. I can't recall who brought it, but our guests from England raved about it and they were right! Their favorite car was the Fuccella's Willys Jeep. Everyone admired the stickers that told of this car's amazing adventures.

We had more children than ever. Peter Uliciansky brought his family and Steve and Teresa Cook showed us that Carly is growing up fast! We had some kinks in our schedule that prevented Andrea from getting yard games set up so we will have to work on that for next year. Cecil, however, got the deck ready well ahead of time this year. He restored it and buffed it to a shine as if it were an antique car.

Finally, what is a Pond house party without a pond? Joe Parsons forgot his fishing pole, but Denny did not. *(Denny caught 25 inches of fish, a total of five fish each 5 inches long.)*

We had a blast hosting the picnic and can't wait to do it again next year. Thanks to all who came and made it a great success!

10. Yates Mill Historic Park September 16, 2017

By Annie Goldman

Yates Mill on Lake Wheeler Road in Raleigh is one of the last operating mills in our part of the state. In addition to the mill itself, their fall festival includes many activities for kids along with displays of wildlife and various crafts. A bluegrass band played on the deck of the museum building. It was just about a perfect day to bring an antique car with lots of shade adjacent to where our cars were parked. Lunch was available from food trucks that were there for the day.



11. Oak View Historic Park Display October 7, 2017

By Denny Oestreich

We were invited by Historic Oak View Park to display our cars at their Heritage Days celebration on October 7, 2017. Members participating were Marv Gage - 1930 Franklin, Carl and Linda Worstell – 1949 Chrysler, John Gillam - 1972 Monte Carlo, William Johnson - 1956 Pontiac Star Chief, and Denny Oestreich - 1957 Chevrolet. Oak View was our previous car show site.



L-R '30 Franklin, '72 Monte Carlo, '49 Chrysler



Marv Gage's 30 Franklin



Franklin, Monte Carlo, Chrysler, Chevy



William Johnson's 1956 Pontiac Star Chief

The weather was a little misty in the morning but turned into a nice day when the fog burned off. Oak View provided great activities for families including animals to pet, 4-H exhibits to see, displays on gardening, pony rides for kids, horse and wagon rides, a blacksmith display and a wood working display. The show was a little smaller this year as there was no quilt auction. The band played great music and lamented the absence of the Tak-A Par T.

We provided a lot of explanations and answered many questions. We also allowed several children to sit behind the wheel and tested them as to whether they were ready to drive or not. The important test was, "Can you reach the pedals?" Oak view provided a free barbeque sandwich lunch for all participants.

Thanks to all who participated.

12. Hershey Pictures October 5-7, 2017

By Denny Oestreich

We have heard via the grapevine 22 Triangle Chapter Members attended Hershey this year including Les and Dean Tryon, Fred and Sue Harley, Riley and Sandra Reiner, Bob and Judy Simpkins, Jim and Becky Aldrich, Brian and Tish White. Don Aikin and son, Joel and Annie Goldman, Bob Gault and Joe Parsons, Chet Butcher, Jack Agayoff, Bob Gault, Joe Parsons, Warren Daniels, and Bob Safrit. We have also heard that three members showed cars. Warren Daniels and Joe Parsons both received their Senior Awards at Hershey and Annie Goldman received an HPOF Recertification.

Dean and Les Tryon's Pictures

Besides the car show and swap meet Hershey is about reunions at Hershey. Here are some pictures of the meeting of friends at the show. Dean said he had 11 members of his Buick Newsletter group stop by to see him. Additionally, they enjoyed dinner with friends and visiting. Here are some of Dean and Les' pictures.



Fred Harley, Dean Tryon, Riley Reiner, Stu Allen and Wolfgang Prochazka



Cpt. Jim Aldrich and Luxury Schooner w/Ghoul



Parts for Sale. Many are still for sale.



Bob and Judy Simpson Stopped By



Sue and Sandra Found the Chocolate in Hershey

Joe Parson's Pictures

Joe took pictures of oddities at Hershey. Did you see them too?



The Ultimate Hershey Hauler



Coming Soon – The Beer Taxi



I told you I needed all that stuff in the garage.



You won't believe all the neat stuff I got at Hershey.

13. Tool Wizard Challenge

By Denny Oestreich
August Mystery Tool

The September mystery tool challenge was not answered. The tool is a Combustion Gas Tester. It is used to determine if combustion gases are getting past the cylinder head gasket and into the coolant. This tool is #75500 from the Lisle Tool company. To use it remove the radiator cap and put the tester into the top of the radiator tank. Then about an inch of green fluid is poured into the sealed glass tube. When the engine is running the hot steam will rise up from the radiator through the liquid. If you put a vacuum source on the long tube the steam will rise up through the fluid in the tester. If there are combustion gases mixed in with the radiator fluid steam the liquid will change color from green to yellow. This means the head gasket is leaking or there is a crack in the head or block. The cylinder compression forces the gases past the leaky head gasket or through the crack in the block into the coolant. If a leak is indicated, you have a serious problem.



October Mystery Tool

Tools submitted by Jim Gill. If you recognize the tool please Email Jim Gill. Tell us the tool name and what is its use. Email Jim Gill at jagpye@bellsouth.net and Denny Oestreich at OestreichD@AOL.com.



14. Shining Light on Headlights for AACA Judging

By Mike Petersen

Article 147

The AACA judging guidelines for headlights are as follows:

1. Headlights must be of the style available when the vehicle was new. Some earlier sealed beam headlights did not have the tips in the lenses for modern alignment tools. Presence of these alignment tips are accepted for early vehicles.
2. Halogen headlights became available in the late 1970's. If you have halogen headlights on a vehicle that was produced prior to general availability then be sure that you have documentation. Remember – it is the responsibility of the owner to provide documentation of components on a vehicle.
3. For a two headlight system the headlights must match in brand and style of the lens.
4. For a four headlight system all four must have the same brand. The high/low beam lights can differ in style from the high beam lights. The high/low beam lights must match and the high beam lights must match. Put another way: All headlights must be of the same brand. The outboard lights do not need to match the inboard lights but the outboard lights must match each other and the inboard lights must match each other.

In recent years halogen headlights have become available for most vehicles that have sealed beam headlights. It is tempting to install these lights but they may not be correct for vehicles produced before they were generally available.

Some owners are not aware that their headlights are halogen lights. When the headlight lens is not marked "HALOGEN" it is difficult to tell halogen from incandescent. If you are an AACA judge it is a good to look at some incandescent and halogen headlights so you can quickly identify one from the other on the show field. Usually the difference between the halogen bulb and the incandescent sealed beam can be determined by the filament that is usually visible through the lens.



Some halogen headlights are obvious. They are marked "HALOGEN" on the lens:

Some halogen headlights are not marked "HALOGEN" but have a halogen bulb inside that can be seen by looking through the lens.

7" Xenon Headlights



Some halogen lights have halogen bulbs with the traditional two-prong or three-prong attachment that look like those used on incandescent headlights. These halogen headlights may be difficult or impossible to detect in which case they should be accepted as correct for years prior to general availability.



An incandescent headlight has a distinct filament that can be seen through the lens. A filament shield may look like the end of a halogen bulb. As a judge if you do not know then there is no deduction.

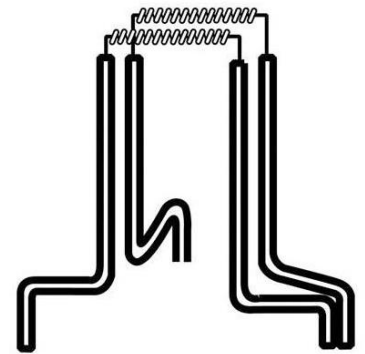
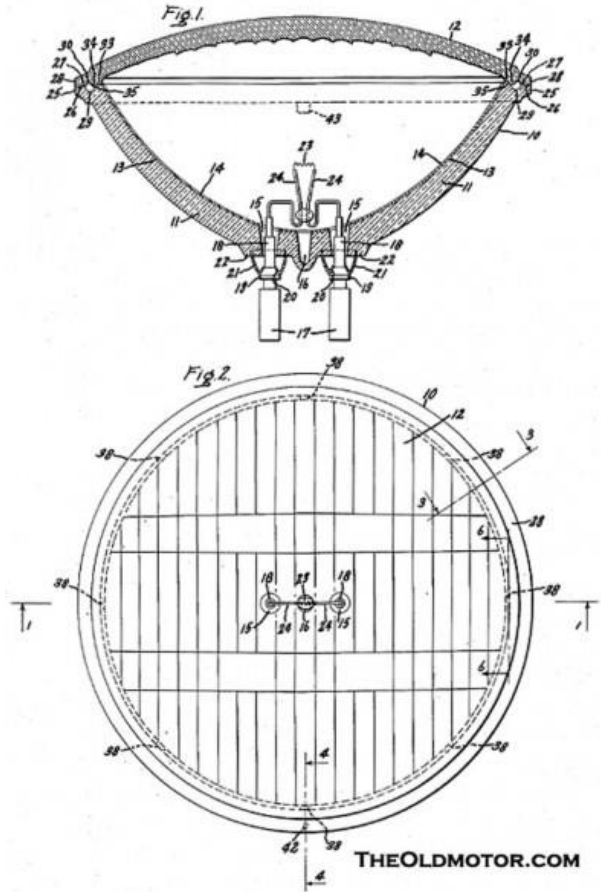
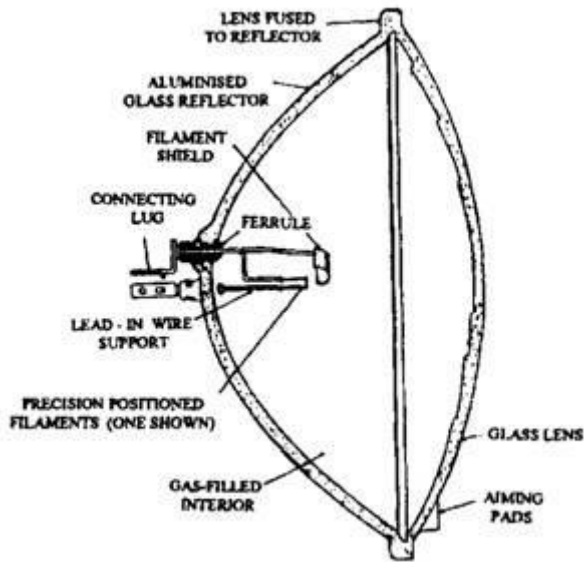

Another look at the incandescent filament inside the sealed beam headlight. This example does not have a shield.

This is what the halogen bulb with standard two-prong or three-prong attachment looks like. These lights can replace incandescent sealed beam lights without any wiring changes:

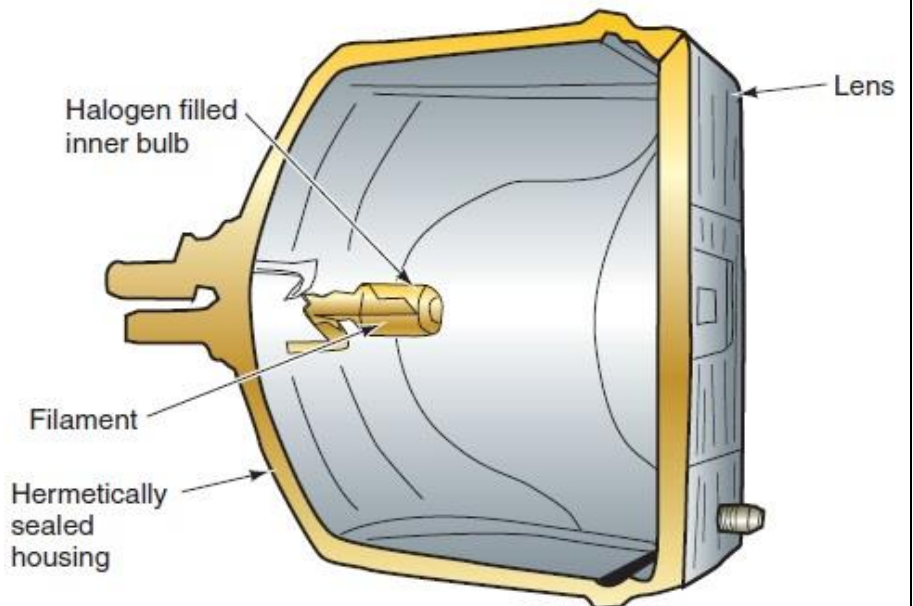



This is the commonly available WAGNER halogen headlight. One can see the halogen bulb inside. It does not look anything like the incandescent filament:

15. For Sale



For Sale:

1957 Chevy 283 Fuel Injection, 283 HP, engine with 3-speed. All parts bought, collected and assembled; fuel filter, distributor, etc. Engine is currently in 57 2Dr Sedan that is 85% restored. Health issues prevent completion. Will sell complete engine and transmission alone, asking \$27K. Will sell the '57 Bel Air car w/engine and transmission \$63K. All parts to complete are included. Work to complete includes; installation of steering column, transmission, radiator, headliner and front seats. Call Larry Dokken at: 919-801-1505 for more details. Email OestreichD@AOL.com for pictures.

16. Triangle Chapter Contacts

Officers

President - Jim Gill (919-363-2616)

Vice President - Dan Fuccella (919-349-5911)

Treasurer - Marv Gage (919-846.4708)

Region News Reporter - Annie Goldman (919-986-0782)

Ex-Officio – Riley Reiner (919-554-1158)

Board of Directors

2016-2017

Chad Goldman (919-475-1470)

Bob Fuhrman (585-519-1543)

Joel Hoffman (919-303-5635)

2017-2018

Henry Burgwyn (919-847-0885)

Jean Soehnlein (919-847-4832)

Fred Harley (919-233-4889)

Committee Chair

Awards - Jim Gill (919-363-2616)

Newsletter Editors - Denny Oestreich (919-846-8163) and Annie Goldman (919-986-0782)

Webmaster - Denny Oestreich (919-846-8163)

Youth Coordinator - Dan Fuccella (919-349-5911)

Car Show Committee – Riley Reiner (919-554-1158)

The End

2018 MEMBERSHIP RENEWAL DUES

Antique Automobile Club of America

North Carolina Region

Triangle Chapter AACA

First Name _____ Last Name _____

Address _____

City _____ State _____ Zip Code _____

Spouses Name: _____ Home Phone No. _____

Email Address _____ Cell Phone No. _____

Cars Owned (Year / Model) _____

NATIONAL AACA: ANNUAL DUES \$40 Required for membership in Region and Chapter Groups

My National number is _____

___ I have paid my 2018 dues directly to AACA National in Hershey

NORTH CAROLINA REGION AACA: Annual dues \$15

___ I have paid my 2018 dues directly to the NC Region

TRIANGLE CHAPTER:AACA ANNUAL DUES \$10

Make Checks payable to: TRIANGLE CHAPTER AACA Note: The above dues can be combined on a single check and the Club will forward your payment to National and or Region.

Mail to: Marv Gage

209 Trotters Ridge Drive

Raleigh, NC 27614

Phone 919-846-4708

Email: mkgage@aol.com

Applicants Signature Date